



FAIRBANKS NIJHUIS™

MODEL 1590F
VERTICAL INLINE FIRE PUMP
INSTRUCTION AND REPAIR MANUAL

NOTE! To the installer: Please make sure you provide this manual to the owner of the equipment or to the responsible party who maintains the system.

ATTENTION: SAFETY WARNINGS:

Read and understand all warnings before installation or servicing pump.

CALIFORNIA PROPOSITION 65 WARNING: **Warning:**

This product and related accessories contain chemicals known to the State of California to cause cancer, birth defects or other reproductive harm.

OPERATIONAL LIMITS: *

Maximum Operating Pressure: 175 psi at Temperatures to 150°F (65.6°C)
Maximum Operating Temperature: 225°F (107°C)

* See ASTM A126/ANSI B16.1 for pressure/temperature ratings of flanges.

ELECTRICAL SAFETY: **Warning:** Electrical Shock Hazard

All electrical connections are to be made by a qualified electrician in accordance with all codes and ordinances. Failure to follow these instructions could result in serious personal injury, death or property damage.

 **Warning:** Electrical Overload Hazard

Insure all motors have properly sized overload protection. Failure to follow these instructions could result in serious personal injury, death or property damage.

 **Warning:** Sudden Start-Up Hazard

Disconnect and lockout power source before servicing. Failure to follow these instructions could result in serious personal injury, death or property damage.

HIGH PRESSURE SAFETY: **Warning:** High Pressure Hazard

The pump is rated at a maximum of 175 psi at 150°F. Do not exceed this pressure. Install properly sized pressure relief valves in system. Failure to follow these instructions could result in serious personal injury, death or property damage.

SERVICE:

Your Fairbanks Nijhuis pump requires little maintenance other than periodic inspection, occasional cleaning, lubrication of bearings and gland adjustments to minimize packing leakage. The intent of inspection is to prevent breakdown, thus obtaining optimum service life. The liquid end of the pump is lubricated by the fluid being pumped and therefore does not require periodic lubrication. The motor, however, may require lubrication, in which case, the motor manufacturer's recommendation should be followed.

REPAIRS:

Before starting any work, ensure the electrical power is locked out, the system pressure has been lowered to 0 psi and temperature of the unit is at a safe level.

The pump may be disassembled using the illustrations and text provided. Although complete disassembly is covered, it will seldom be necessary to completely disassemble your Fairbanks Nijhuis pump.

Inspect removed parts at disassembly to determine if they can be reused. Ball bearings that turn roughly or show wear should be replaced. Cracked casings should never be reused. Scored or worn pump shafts should be replaced. Gaskets should be replaced at reassembly simply as a matter of economy. They are much less expensive to replace routinely than to replace as the need arises. In general it is economical to return to the manufacturer for repair of only the motor and motor controller.

DISASSEMBLY:

Disassemble only what is needed to make repairs or to accomplish inspection. Proceed to disassemble the pump as follows:

1. Break electrical connections to prevent any possibility of pump starting during disassembly.
2. Remove plug (74) from casing (6) to drain pump.
3. Remove all relief, cooling, flushing, or drain lines from the pump including compression connections (1 & 2), ball valve (75) and tubing (3) if provided. Break suction and discharge connections only if it is desired to remove casing (6).
4. Remove capscrews (5) and two opposite capscrews (41). Thread two capscrews (5) into taps that held capscrews (41) and turn alternately until cover (26) separates from casing. This procedure may vary slightly for some pump sizes. Lift pump assembly with motor from casing (6). Remove gasket (8).

 **Warning:** Lifting Hazard

The motor and pump assembly may be very heavy. Use extreme caution and safe lifting equipment during the lifting procedure. Failure to follow these instructions could result in serious personal injury, death or property damage.

5. Unscrew impeller screw (9) and remove washer (9A), gasket (9B) and seal washer (9C).
6. Slide impeller (11) and impeller key (12) from the shaft. Remove O-ring (10).
7. Wearing ring(s) (7 & 16) are pressed into their housings with an interference fit and must be removed with a puller if new rings are required.
8. Remove capscrews (65), gland clamps (22), and gland halves (23).
9. Unscrew remaining capscrews (41) and remove cover assembly (26).
10. Shaft sleeve (25) is slip fit on the shaft and should be easily removed unless the pump has been in service for a long time. In this case, it may be necessary to use a puller. Take care to prevent damaging the surface of the sleeve. Replace the sleeve if it is grooved from wear.
11. The packing (28) and lantern ring (29) (if used), must now be removed from the packing box of cover (26), and the cavity thoroughly cleaned to allow new packing to fit properly. The throat of cover (26) should be checked for excessive wear.
12. If necessary, unscrew capscrews (32) and remove bracket (35) from motor.

REASSEMBLY:

Reassembly will generally be in reverse order of disassembly. If disassembly was not complete, use only those steps related to your particular repair program.

1. Replace wear ring(s) (7 & 16) in casing (6) and cover (26). Rings should not be hammered into place. Use a press or clamp the parts in a bench vise using wooden blocks to protect the rings. It may be necessary to pin or dowel the rings after assembly if the cover or casing has had rings replaced before, since each reassembly can stretch or tear metal and thereby loosen fits. If the facilities are available, it is good practice to take a very light finish cut or to ream the inside diameter of the casing rings after pressing to restore roundness. When rings are pressed, they may get squeezed out of shape.
2. If bracket (35) was removed, position the motor and secure with capscrews (32). Tighten screws evenly to assure proper alignment.
3. Place one ring of packing (28) into cover (26). On successive rings of packing, stagger the packing joints to prevent excessive leakage through the packing box. If lantern ring (29) is used, place a second ring of packing (28) into the cover before installing lantern ring.

CAUTION

There must be two (2) rings of packing in front of lantern ring (29) to assure proper alignment between the lantern ring and the sealing tube connection (1) in the cover (26). Install remaining packing rings (28). Each ring should be tapped

firmly in place with a wood or metal bushing.

4. Slide the sleeve (25) through the packing making sure the pin end of the sleeve (25) is in the cover side opposite the gland halves (23).
5. Replace gland halves (23) and place gland clamps (22) over capscrews (65). Tighten capscrews (65) finger tight into cover assembly (26).

NOTE:

The slots in gland halves (23) should be diagonal to pump horizontal center line.

6. The cover assembly (26) as a unit may be replaced onto the motor shaft. Align key groove to facilitate impeller reassembly. The cover is held to motor bracket (35) by capscrews (41). These should be installed and tightened at this time.
7. Carefully place O-ring (10) on motor end of impeller (11). Assemble key (12) and impeller (11) to motor shaft. Secure impeller with gasket (9B), washer (9A), seal washer (9C), and impeller screw (9).
8. Install the pipe plug (74) in the pump casing (6). Position a new gasket (8) on casing (6). Lower bracket, cover, and motor assembly onto casing and secure with capscrews (50).
9. If provided, replace compression fittings (1 & 2), ball valve (75), and tubing (3).
10. Secure suction and discharge piping to the pump. Make sure to install gaskets on flanged connections.
11. Connect electricity to the motor.
12. Read carefully the sections of the manual titled INSTALLATION and OPERATION.

STARTING PUMP AFTER REASSEMBLY:

Do not start pump until all air and vapor has been bled and until making sure that there is liquid in the pump to provide the necessary lubrication for the packing.

When the pump is returned to service, additional care must be given to packing box to ensure a proper packing life. It is necessary to allow 60–120 drops leakage per minute through the packing for lubrication purposes. If the flow rate is other than this, the capscrews should be either loosened or tightened one quarter turn at a time to acquire the correct leakage (both capscrews must be turned equally to prevent cocking of the gland). It will take approximately ten minutes at any one gland setting before the leakage rate will stabilize. When in doubt, choose the greater leakage rate since overly tight packing will ruin not only the packing, but the sleeve as well.

MODEL 1590F LIST OF PARTS

1. Compression Fitting	9A. Washer	25. Sleeve	40. Nameplate Holder
2. Compression Elbow	9B. Gasket	26. Cover	41. Capscrew
3. Tubing	9C. Seal Washer	28. Packing	65. Capscrew
4. Pipe Plug	10. Gasket	29. Lantern Ring	68. Pipe Plug
5. Capscrew	11. Impeller	32. Capscrew	73. Base
6. Casing	12. Impeller Key	33. Screw	74. Pipe Plug
7. Wear Ring	16. Wear Ring	34. Nameplate	75. Ball Valve
8. Gasket	22. Clamp	35. Bracket	76. Nipple
9. Impeller Screw	23. Gland	39. Capscrew	

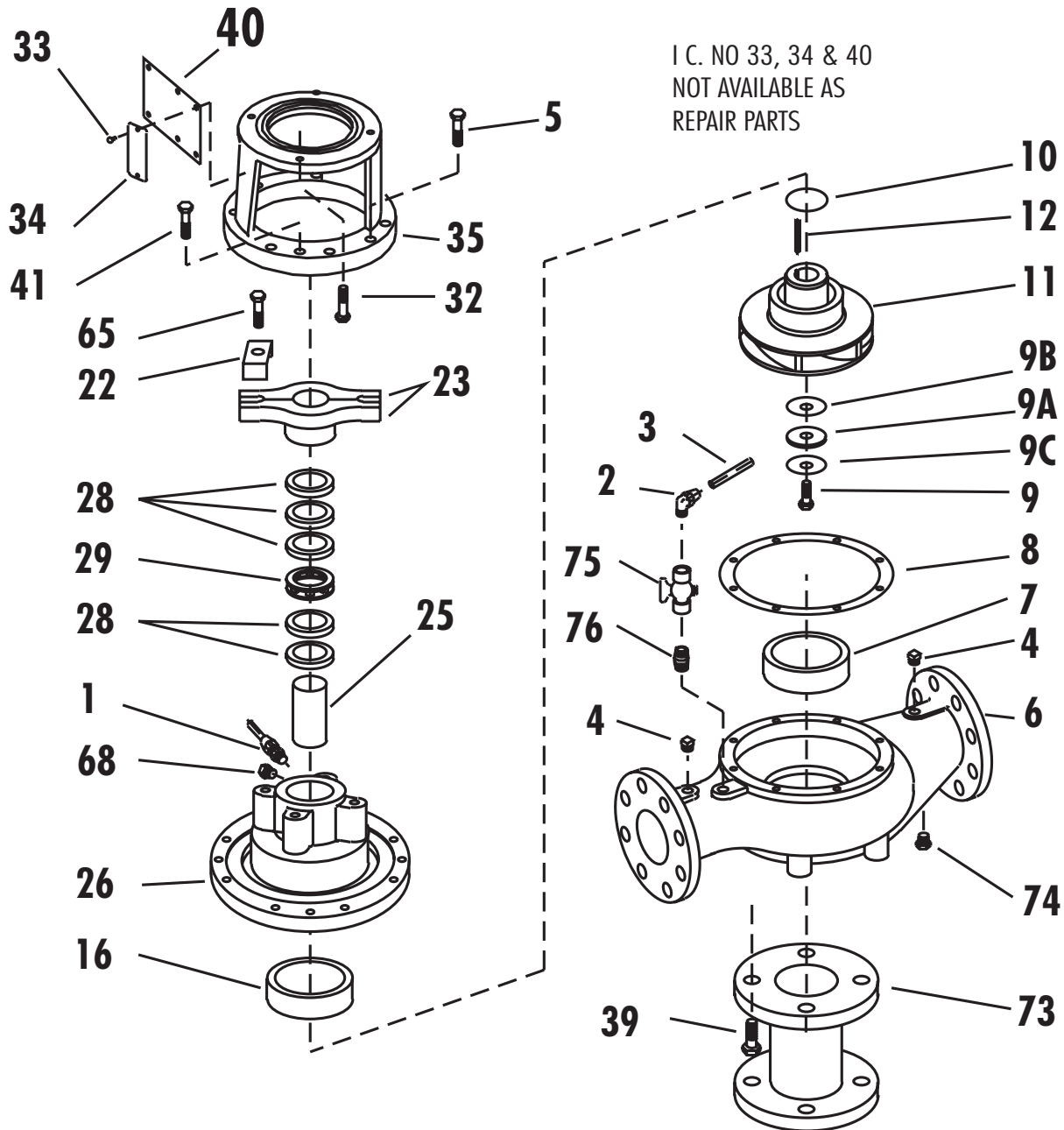
**NOTE:**

When ordering spare parts always include the pump type, size, serial number and piece number from the exploded view in this manual.